

Features

- Operating voltage: 2.4V~12V
- Low power and high noise immunity CMOS technology
- Low standby current
- 3¹⁵ address codes
- Built-in oscillator needs only 5% resistor
- Three times transmission
- Check received address twice
- Valid transmission indicator
- 1 momentary, 1 toggled data output
- Easily interface with an RF or an infrared transmission medium
- Minimal external components

Applications

- Burglar alarm system
- Smoke and fire alarm system
- Garage door controllers
- Car door controllers
- Car alarm system
- Security system
- Cordless telephones
- Other remote control systems

General Description

The 3¹⁵ encoder/decoder are a series of CMOS LSIs for remote control system applications. The encoder section encodes 15 bits of address and serially transmits the encoded data upon receipt of a Transmit Enable (TE) signal. The decoder section, on the other hand, receives the 15-bit word and interprets all the 15 bits as

address. If the encoder sends an address that matches the address of the decoder, the VT pin goes high on the decoder and the the TGO pin toggles once simultaneously. When the STATUS pin is high, the device is in the process of encoding. Otherwise, it is in the standby state or in the decoding condition.

Package Information

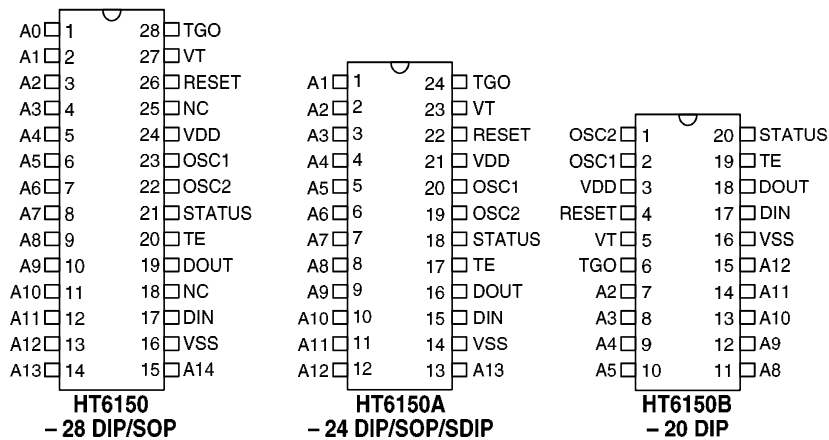

Block Diagram

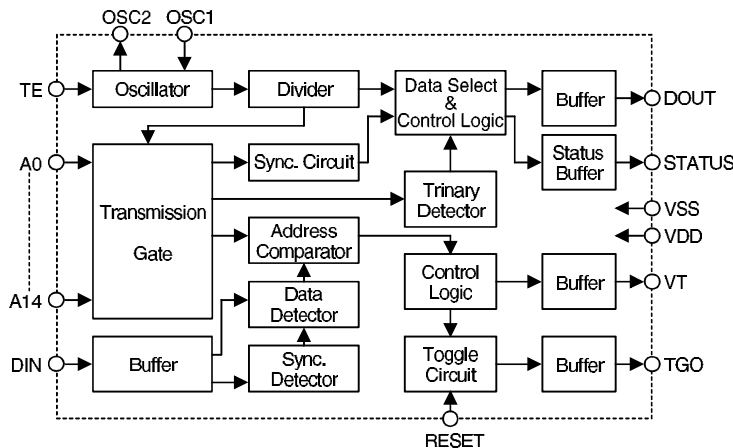

Pin Description

(28 DIP)

Pin Name	I/O	Internal Connection	Description
A0~A14	I	TRANSMISSION GATE	Input pins for address A0~A14 setting. They can be externally set to VDD, VSS, or left open.
STATUS	O	CMOS OUT	Encoder enable indicator, active high
RESET	I	CMOS IN Pull-Low	Decoder reset pin for clearing TGO
DIN	I	CMOS IN	Decoder data serial input
DOUT	O	CMOS OUT	Encoder data serial transmission output
VT	O	CMOS OUT	Valid transmission indicator output, active high
TGO	O	CMOS OUT	Toggle output for the decoder
TE	I	CMOS IN Pull-Low	Transmission enable, active high
OSC1	I	OSCILLATOR	Oscillator input pin
OSC2	O	OSCILLATOR	Oscillator output pin
VSS	I	—	Negative power supply (GND)
VDD	I	—	Positive power supply

Approximate internal connection circuits

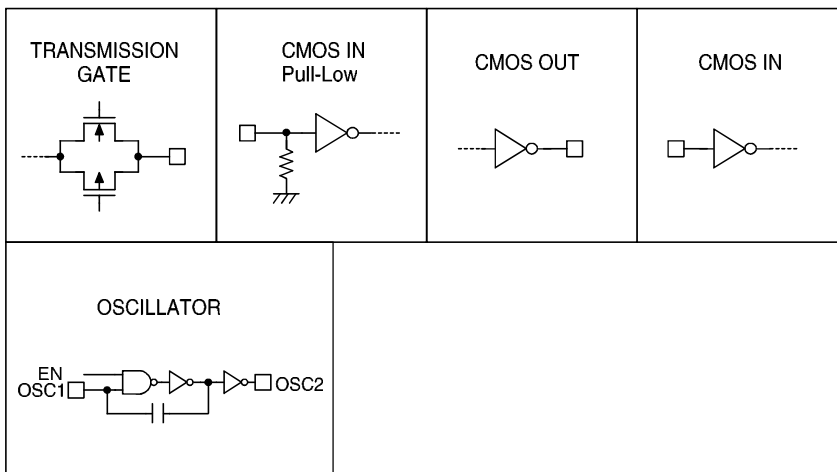

Absolute Maximum Ratings*

Supply Voltage -0.3V to 13V Storage Temperature..... -50°C to 125°C
 Input Voltage..... $V_{SS}-0.3$ to $V_{DD}+0.3V$ Operating Temperature..... -20°C to 75°C

*Note: Stresses above those listed under “Absolute Maximum Ratings” may cause permanent damage to the device. These are stress ratings only. Functional operation of this device at these or any other conditions above those indicated in the operational sections of this specification is not implied and exposure to absolute maximum rating conditions for extended periods may affect device reliability.

Electrical Characteristics

($T_a=25^\circ C$)

Symbol	Parameter	Test Conditions		Min.	Typ.	Max.	Unit
		V _{DD}	Conditions				
V _{DD}	Operating Voltage	—	—	2.4	—	12	V
I _{STB}	Standby Current	3V	Oscillator stops	—	0.1	1	μA
		12V		—	2	4	μA
I _{DD}	Operating Current	5V	No load	—	250	500	μA
		12V	F _{OSC} =100kHz	—	600	1200	μA
I _{OUT}	Output Drive Current for DOUT, STATUS, VT, TGO Pins	5V	V _{OH} =0.9V _{DD} (Source)	-0.6	-1.2	—	mA
		5V	V _{OL} =0.1V _{DD} (Sink)	2	4	—	mA
V _{IH}	“H” Input Voltage	—	—	0.8V _{DD}	—	V _{DD}	V

Symbol	Parameter	Test Conditions		Min.	Typ.	Max.	Unit
		V _{DD}	Conditions				
V _{IL}	"L" Input Voltage	—	—	0	—	0.2V _{DD}	V
F _{OSC}	Oscillator Frequency	10V	R _{OSC} =390kΩ	—	100	—	kHz
R _{TE}	TE Pull-Low Resistance	5V	V _{TE} =5V	—	1.5	3	MΩ

Functional Description

Encoder section operation

The 3¹⁵ series of encoder begin a three-word transmission cycle upon receipt of a transmission enable (TE, active high). This cycle will repeat itself as long as the transmission enable (TE) is held high. Once the transmission enable falls low the encoder output completes its final cycle and then stops as shown below.

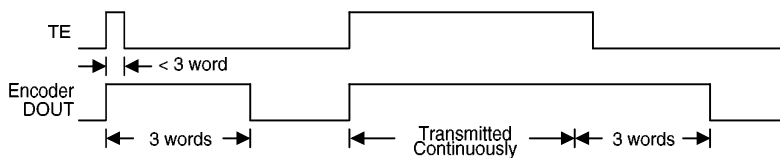

Transmission timing

Encoder section information word

An information word is composed of three periods as shown:

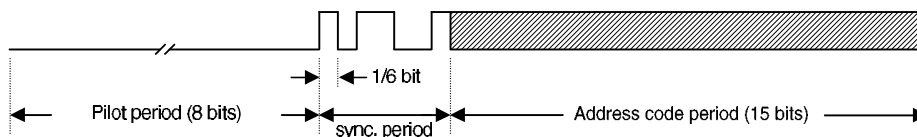

The 3¹⁵ series of encoder detects the logic state of address (A0~A14) and transmits the detected data during the address code period. Each address pin can be set to one of the following three logic states:

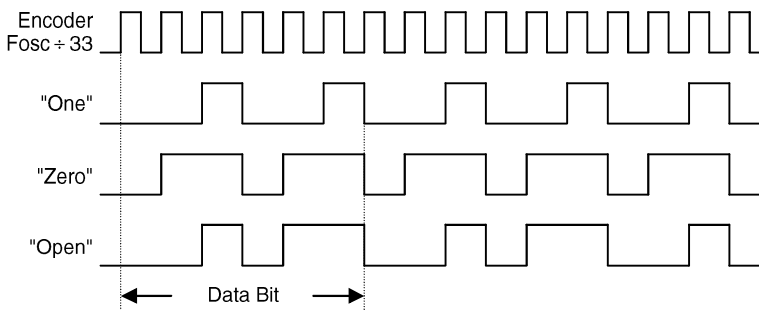

Encoder flowchart

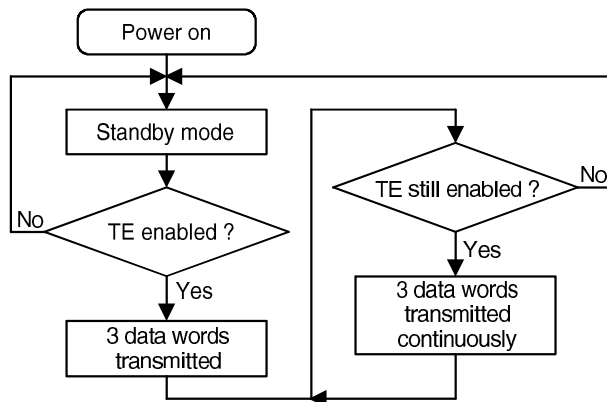

Decoder section operation

A signal on the DIN pin activates the oscillator which in turn decodes the incoming address. The decoder then checks the received address twice continuously. If all the received address codes match the contents of the decoder's local address, the TGO pin toggles once and the VT pin is set high to indicate a valid transmission. That will last until the address code is incorrect or no signal has been received. The output of the VT pin is high only when the transmission is valid. Otherwise it is always low. The output of the TGO pin can be cleared low by a RESET signal (active high).

Decoder flowchart

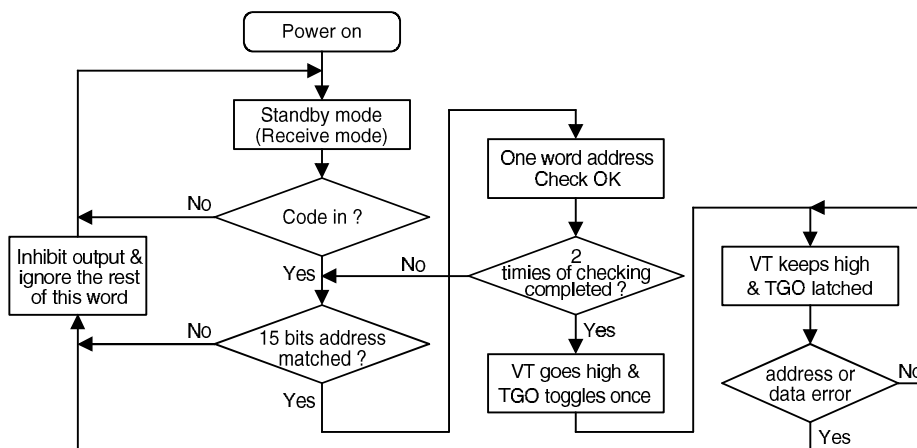

Note: The oscillator is disabled in the standby state and activated as long as a logic "high" signal is applied to the DIN pin. i.e., DIN should be kept "low" if there is no signal input.

Decoder timing

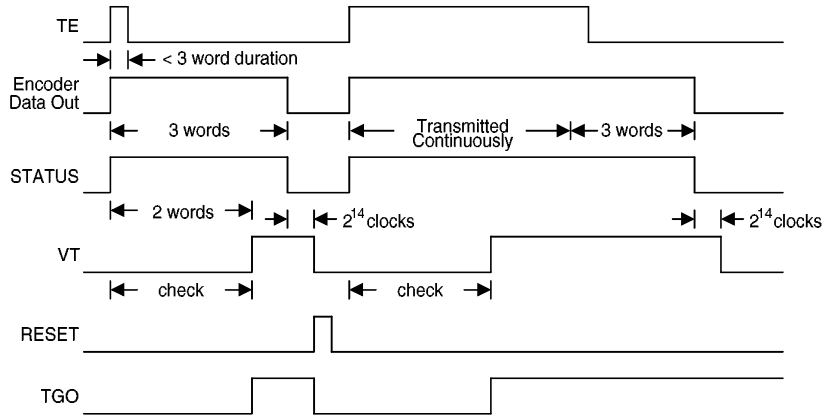

Oscillator frequency vs supply voltage

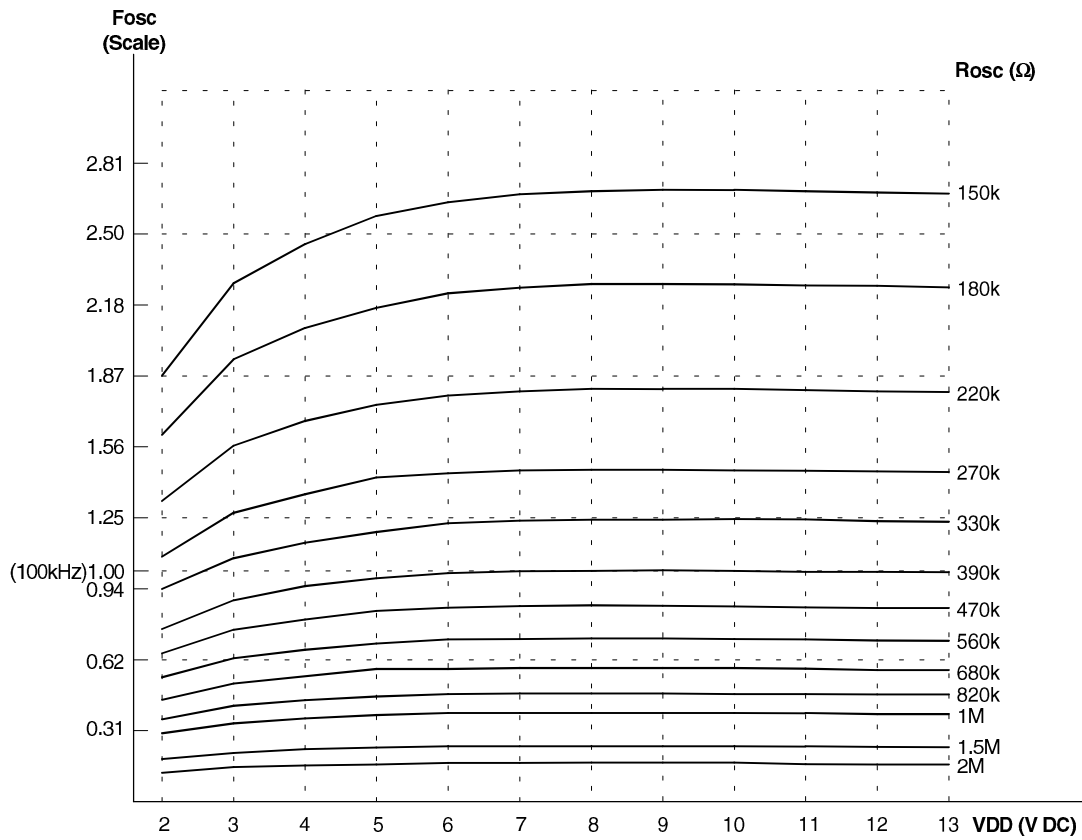

The recommended oscillator frequency is F_{OSCD} (HT6150 decoder) ≅ F_{OSCE} (HT6150 encoder).

Application Circuits

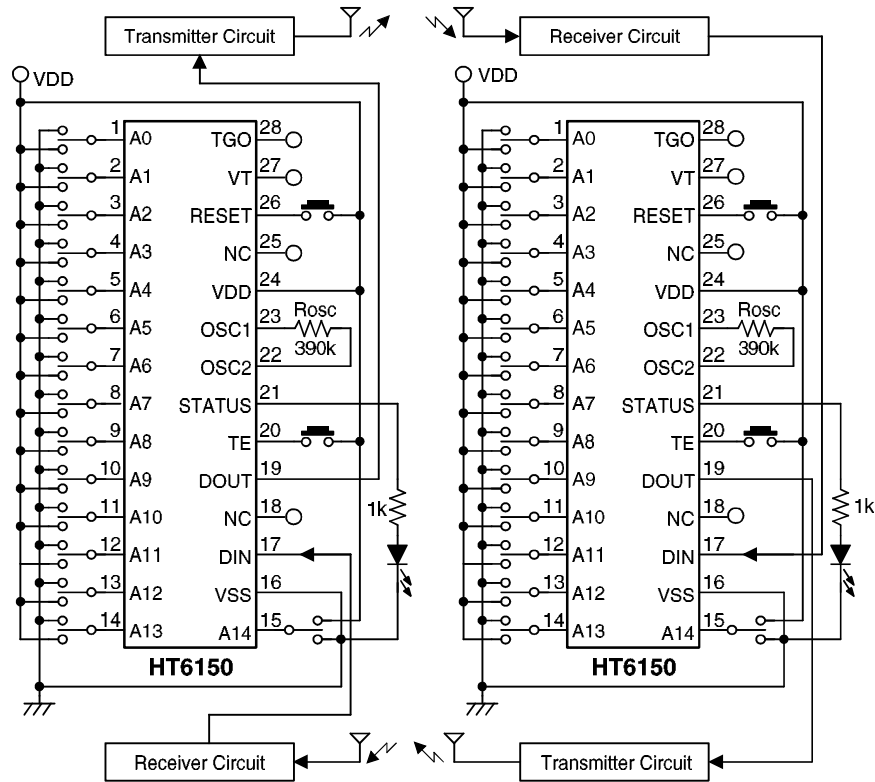

Note: Typical infrared diode: EL-1L2 (KODENSHI CORP.)
 Typical RF transmitter: JR-220 (JUWA CORP.)
 Typical infrared receiver: PIC-12043T/PIC-12043S (KODESHI CORP.)
 or LTM9052 (LITEON CORP.)
 Typical RF receiver: JR-200 (JUWA CORP.)